



Installation Instructions Avalanche "XUV" Cap



IMPORTANT!

Read all instructions carefully before commencing any work. Always wear safety equipment. Some installation steps will require two or more installers.

Recommended tools

Ratchet	Torque wrench
T30 Torx clothe	Wiping
Phillips Screw Driver	Window cleaner
Drill motor	3/8 th drill bit



IMPORTANT!

A. Remove the vehicle jack and any other items from the top box storage compartments on either side of the truck bed. These compartments will not be accessible when the "XUV" cap is installed.

B. Vehicle and "XUV" cap preparation:

1. Wipe the bottom seal surface of the "XUV" cap to remove dirt and debris.
2. Clean the outside top surface of the vehicle's cab with a soft non-abrasive cloth.
3. Clean the top of the bed rails and tailgate.
4. Remove the vehicle 3 panel cargo cover and set it aside. It can be reinstalled after the "XUV" cap installation is complete.
5. Remove the center bolt from each of the rear hand holds (driver and passenger sides). See **photo 1**. These bolts should be reinstalled when the "XUV" cap is removed.



Photo 1

6. Remove the two outer and two inner bolts from the vehicle roll bar cladding. See **photo 2**. These bolts should be reinstalled when the "XUV" cap is removed.

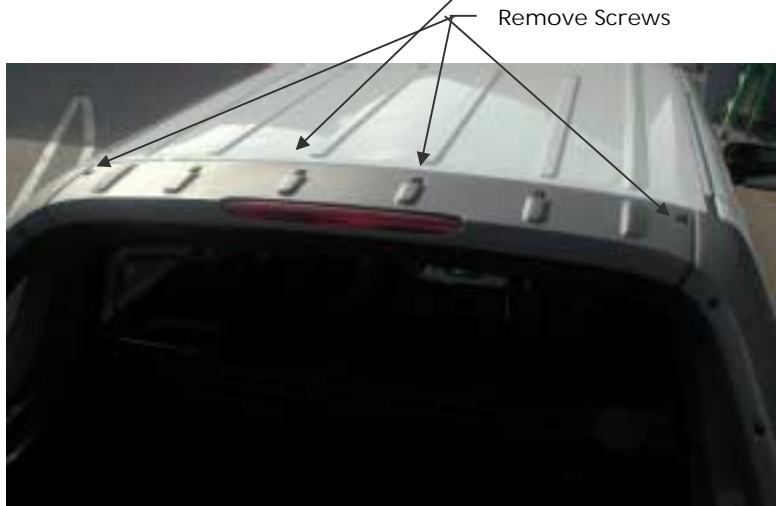

Photo 2

7. Install the clear "Cab Skin" provided in your installation kit. Bridge from the plastic cladding to the metal of the cab, see **photo 3**.



Photo 3

C. Third brakelight installation:

1. Remove the driver side taillight lens. You will need to remove two screws to do so. See **photo 4**.

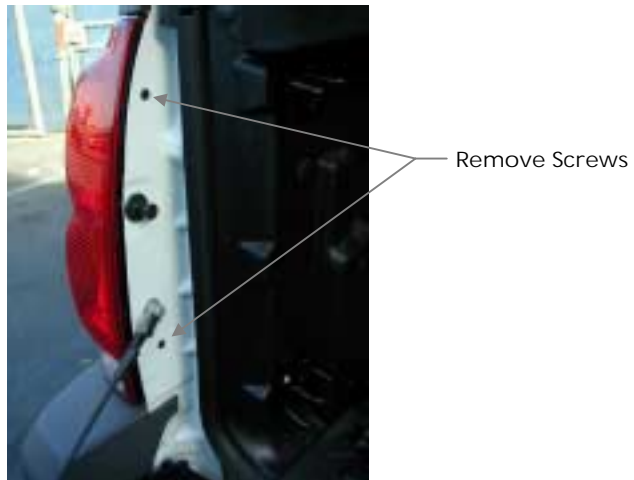

Photo 4

2. Drill a 3/8in diameter hole in the driver side rear plastic side cover. See **photo 5**.
3. Run the plug wire through the hole and into the taillight opening.
4. Connect the plug wire to the fuse wire using the bullet connectors.
5. Attach the black wire on the fuse holder to the blue vehicle wire at the top reflector. Use the linesman pliers to crimp the pink connector in the wiring kit for this connection. See **photo 6**.



Photo 5

Drill 3/8" Hole

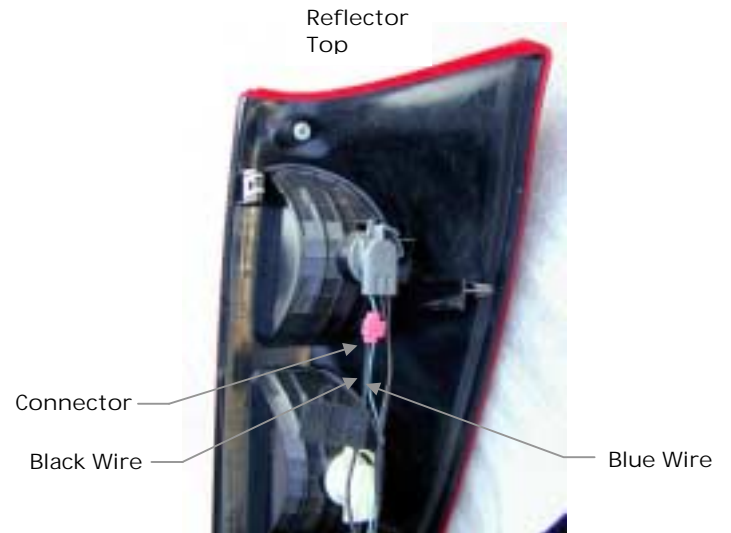

Photo 6

6. Attach the black ground wire to the vehicle body. Make sure you drill into the forward facing bulkhead of the taillight recess. **Carefully view photo 7 for location.**



Photo 7

7. Reinstall the taillight lens.

D. Installing the Porthole Windows:

1. Place the porthole window in the opening. See **photo 8**.
2. Place the inner fiberglass plate in the opening on the inside of the truck.
3. Tighten the thumbscrew until the window is held firmly in place. See **photo 9**.



Photo 8



Photo 9

E. Installing the "XUV" cap:

1. Place the "XUV" cap on the bed rails and slide it forward until the holes in the cap rail line up with the holes in the truck bed. Please refer to **photo 10**. (This operation requires at least two people). The "XUV" cap tailgate flange should not contact the vehicle's tailgate.
2. To secure the "XUV" cap to your vehicle, begin by loosely installing the two 90mm bolts in the rear cap rail. See **photo 11**.



Photo 10



Photo 11

Height Setting Block

3. Loosely install the four 70 mm bolts at the front of the "XUV" cap.
4. It is important to tighten the bolts in the proper sequence. First tighten the two center front bolts and then the two outer front bolts. Tighten these bolts so that the $\frac{1}{4}$ " thick rubber height setting blocks are slightly depressed. See **photo 11**. **These height-setting blocks should be removed when the installation is complete.**
5. Tighten the two 90mm bolts at the rear of the "XUV" cap rails. These bolts should be tightened to about 50in-lbs.

6. Install the black plastic caps over the four bolts on the front of the cap. See **figure 1**.

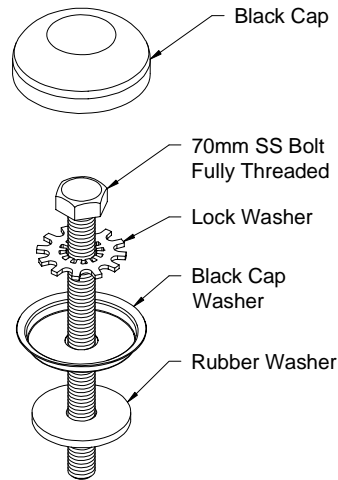

Figure 1. Cap Front Install Hardware

F. Rotary latch tailgate adjustment.

1. The rotary latch tailgate fit and function may be easily adjusted by simply loosening a few Phillip head screws. To adjust the fit (depth when closed) of your tailgate, loosen the two Phillip head screws on the rotary latch assembly and move it down to push the tailgate away from the "XUV" cap when closed, or up to move the tailgate towards the "XUV" cap when closed. To adjust the function (latch engagement) of your tailgate, begin by inspecting the mechanism to determine the direction of the adjustment needed. Next, loosen the two Philip head screws on the strike loop and move it to the desired position. Please refer to **Figure 2**.

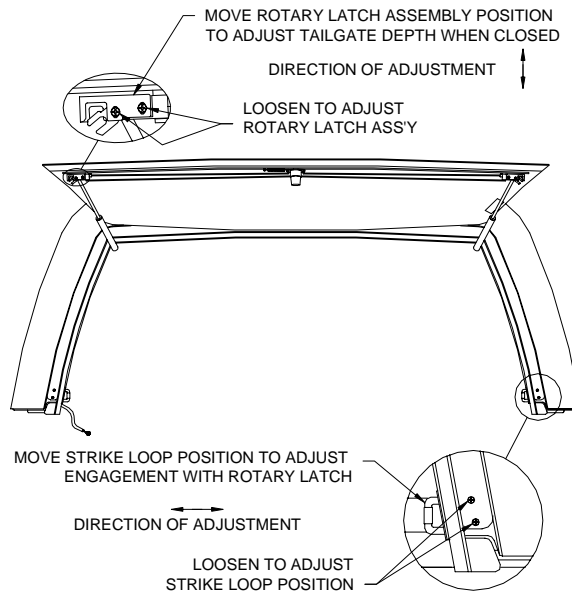

Figure 2. Rotary Latch Tailgate Adjustment

Important care instructions for your SNUGTOP

Your SNUGTOP will give you years of trouble free service if you follow these recommendations:

- ◆ Prolong the life of the painted surfaces by waxing your SNUGTOP every four to six weeks with a high quality car or boat wax. (Wait approximately 30 days from the time of purchase before waxing to allow for maximum cure of the finish.)
- ◆ Always wash your SNUGTOP in a shaded area.
- ◆ Do not wipe painted surfaces with a dry cloth.
- ◆ Do not use any abrasive cleaners.
- ◆ Lubricate all moving door lock parts once a month with an oil base lubricant. Do not use any silicon or petroleum distillate (WD-40) type spray lubricants.

NOTE: Contact your dealer regarding availability of products that protect truck surfaces against scuffing and/or chafing.



WARNING!

- ◆ Truck caps are not designed to serve as a passenger compartment.
- ◆ State laws prohibit carrying passengers in the bed of a pickup truck.
- ◆ Do not occupy pickup truck box while the engine is running or the vehicle is in motion.
- ◆ Serious or fatal injury may occur from collision or carbon monoxide poisoning.
- ◆ Always keep your "XUV" cap door closed while driving your vehicle.
- ◆ All mounting hardware requires regular inspection and occasional tightening. If you detect any wear or corrosion on mounting hardware, contact your dealer or the manufacturer for a replacement.
- ◆ This "XUV" cap is weather resistant but not weather proof. Please take appropriate measures to ensure the safety of any items of value.
- ◆ This product is not a "Roll Bar," in case of an accident it does not provide protection to the occupants of the vehicle.
- ◆ Protect yourself and others – buckle up!
- ◆ Make other family members aware of these warnings.

If you have any questions or problems please call Snugtop Customer Service at 1-800-SNUGTOP.